

DEMA[®]

USER MANUAL

910N



10 Gallon Air Operated Portable Foam
Equipment

English (Original Instructions)

READ ALL INSTRUCTIONS BEFORE OPERATING EQUIPMENT

WARNING



Read this manual completely and understand the machine before operating or servicing it.

- Always wear protective clothing, gloves, and eyewear while operating or servicing unit.
- Avoid contact of cleaning agent with skin and eyes. If contact occurs, see MSDS sheet for further first aid measures.
- Follow safety instructions of chemical manufacturer (MSDS).
- Never point the discharge wand at anyone.
- Incoming air pressure cannot exceed 100 psi (7 bar).
- After each use, relieve all remaining pressure in the system by unplugging the air line from the unit and opening the discharge ball valve to prevent accidental discharge.
- After relieving the pressure from the unit, store the unit with the ball valve in the closed position.
- Be sure to flush the unit with fresh water for 5 minutes when switching from an alkaline to an acid or an acid to an alkaline.
- Do not exceed a fluid temperature of 100°F (37°C).
- Only use clean and dry air. Air must be filtered and free of moisture or pump life will be diminished. If needed, install an air dryer before unit.
- Do not use air lubricator before the unit.

PROTECT THE ENVIRONMENT

Please dispose of packaging materials, old machine components, and hazardous fluids in an environmentally safe way according to local waste disposal regulations.



Always remember to recycle.

*Specifications and parts are subject to change without notice.

Specifications:

Hose	20 feet reinforced hose, 1/2 inch inside diameter (6 meters reinforced hose, 12.7 mm inside diameter)
Foam Output.....	15 to 30 gallons/minute (57 to 144 liters/minute)
Foam Distances	15 to 20 feet (4.6 to 6 meters)
Liquid Temperature	40°F to 100°F (4.4°C to 37°C)
Noise Level.....	Average 79 dB(A)
Discharge Wand Vibration Level	Maximum 2.5 m/s ²

Dimensions:

Length	19 in (483 mm) approximately
Width	16 in (406 mm) approximately
Height	41 in (1041 mm) approximately
Weight, including discharge hose and wand:	
(Empty)	39 lbs (18 kg) approximately
(Full)	138 lbs (63 kg) approximately

Requirements:

Compressed Air Pressure Requirements: Air regulator (R25) factory set at 50 psi (3.4 bar). Operating range is 40 to 80 psi (3 to 5 bar) with 3.5 to 8 CFM (99.1 to 227 l/min)

Chemical requirements: follow all instructions from chemical manufacturer.

Air Operated Double Diaphragm Pump Models Offered:

P56: Polypropylene body with Santoprene diaphragm

P56V: Polypropylene body with Viton diaphragm

P56K: Polypropylene body with Kalrez diaphragm

Acceptable Products:

Alkaline cleaners, Caustic cleaners, Sanitizers, and Acids

* D-Limonene may only be used with Kalrez pump

* Chlorine may only be used with Viton or Kalrez pump

DO NOT USE: All hydrocarbons

READ ALL INSTRUCTIONS BEFORE OPERATING EQUIPMENT

Operation Instructions:

1. Follow all instructions from chemical manufacturer. Fill the tank with water and the advised percentage of chemical concentrate.
2. With ball valve (HV60) in the closed position, plug an air line into the air fitting (AP25).
3. Slowly open the ball valve (HV60) completely.
4. Adjust the needle valve (NV14Y) to desired wetness or dryness of foam following the steps below:
 - a. Close needle valve completely in clockwise direction.
 - b. Open needle valve in counter-clockwise direction 3 complete turns.
 - c. Continue to open valve in ¼ turn increments allowing 30 seconds between adjustments until proper consistency of foam is achieved.

After Use Instructions:

1. Flush the unit with fresh water for 5 minutes.
2. Disconnect the air line from the air fitting (AP25) and relieve any remaining pressure in the system by opening the discharge ball valve (HV60).
3. Close the ball valve (HV60) after all pressure has been relieved from the system.

Maintenance Instructions:

To keep your portable tank foamer operating properly, periodically perform the following maintenance procedures:

- Check the air pump (P56/P56K/P56V) for wear and leaks.
- Inspect hoses for leaks or excessive wear. Make sure all hose clamps are in good condition and properly secured.
- Replace filter (AFR25) in regulator (R25) as needed.
- Check the suction tube and screen for debris and clean as needed.
- Drain compressor tank on a regular basis to ensure proper operation of pump.

Troubleshooting Instructions:

- Check to ensure the discharge hose is uncoiled properly, and that there are no kinks that could obstruct fluid flow.
- Check air regulator bowl (ABR25) for debris such as water, oil, or rust particles. Clean by unthreading the air regulator bowl from the air regulator (R25).
- If needle valve (NV14Y) valve is open too far, the pump (P56/P56K/P56V) will cycle improperly due to lack of air pressure. If this occurs, reset needle valve as described in Operation Instruction #4.
- Make sure proper foaming chemical and concentration is being used.

- If air passes through the pump (P56/P56K/P56V) without cycling, the pump needs to be replaced.
- If foam solution backs up into air regulator bowl (ABR25), the check valve (CV38) needs to be replaced.
- If foam comes out wet, no matter where the needle valve (NV14Y) is positioned, the check valve (CV38) may need to be replaced.
- Check for proper air pressure on air gauge (AG100). Air regulator (R25) is factory set at 50 psi (3.4 bar). Operating range is 40 to 80 psi (3 to 5 bar) with 5 to 10 CFM (141.64 to 283.30 l/min)
- If the unit foams at a reduced pressure:
 - o Check the air compressor supplying the unit. If the pressure is less than 40 psi, turn the foam unit off until the compressor can catch up.
 - o If the air supply is 50 psi (4.14 bar) or above, check the AG100, which should read near 50 psi (4.14 bar). If the AG100 is more or less than 50 psi (4.14 bar), adjust the pressure by turning the knob on the top of the air regulator (R25).
 - o If both of the above are okay, the stainless steel mixing mesh (SS-MESH) could be plugged. Remove and clean it by following the instructions below:
 1. Be sure the foam unit is not plugged into an air supply and be sure to relieve all stored pressure in the unit by having the ball valve (HV60) in the open position.
 2. Remove the stainless adaptor (SSA12) from the tee fitting (SST12HB38).
 3. Remove the screen and the mixing mesh from inside the tee fitting (SST12HB38).
 4. Clean any particles from the mixing mesh and the screen.
 5. Replace the mixing mesh and then the screen into the back of the tee and screw the stainless adaptor back into the tee. It is recommended to use a pipe thread sealant when reinstalling the stainless adaptor back into the tee fitting (SST12HB38). If the mixing mesh has a lot of foreign particles in it, make sure the strainer (STR38-IL) is still in place.
- Check for plugged strainer (STR38-IL). Replace strainer if necessary. Strainer must be used.

READ ALL INSTRUCTIONS BEFORE OPERATING EQUIPMENT

**TANK ASSEMBLY
ITEM NUMBER: TANK-10N-A**

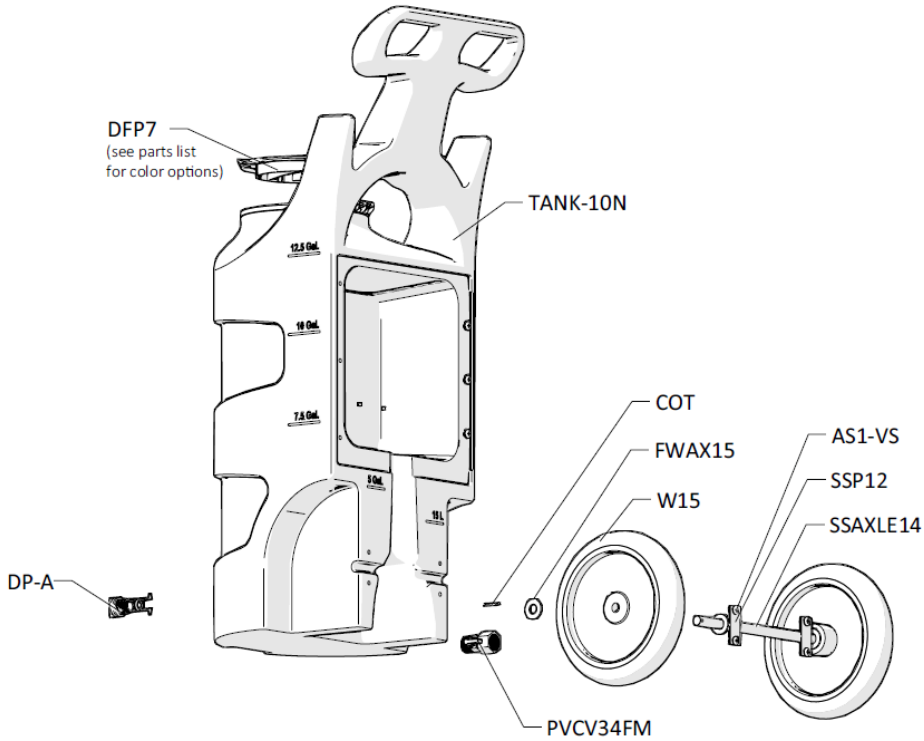

**HOSE AND WAND ASSEMBLY
ITEM NUMBER: SSWA12-HA20**

**ZERO TIP FOAM WAND ASSEMBLY
ITEM NUMBER: SSWA12**

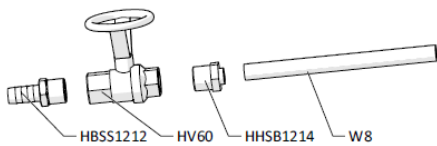

**20 ft (6 m) HOSE ASSEMBLY
ITEM NUMBER: H12-20**

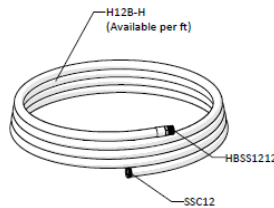

**FAN TIP FOAM WAND ASSEMBLY
ITEM NUMBER: PWA12-ST**

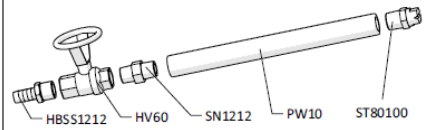

**ANTI-KINK SPRING ASSEMBLY
ITEM NUMBER: AKSS12**

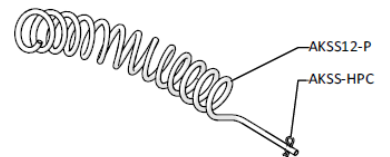

READ ALL INSTRUCTIONS BEFORE OPERATING EQUIPMENT

PLATE ASSEMBLY

ITEM NUMBER (Santoprene pump): PA-PF

ITEM NUMBER (Kalrez pump): PA-PFK

ITEM NUMBER (Viton pump): PA-PFV

Plate - Inside View

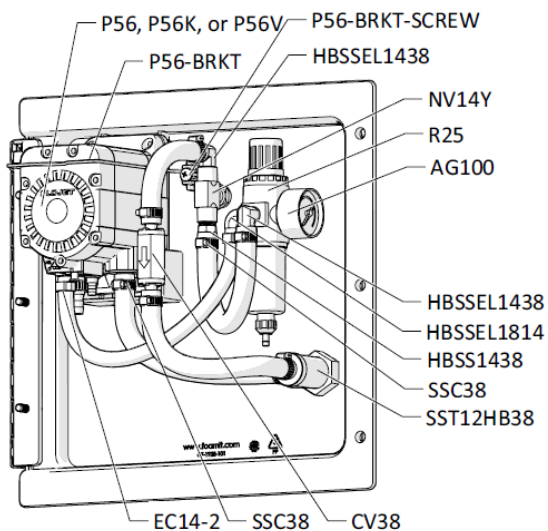
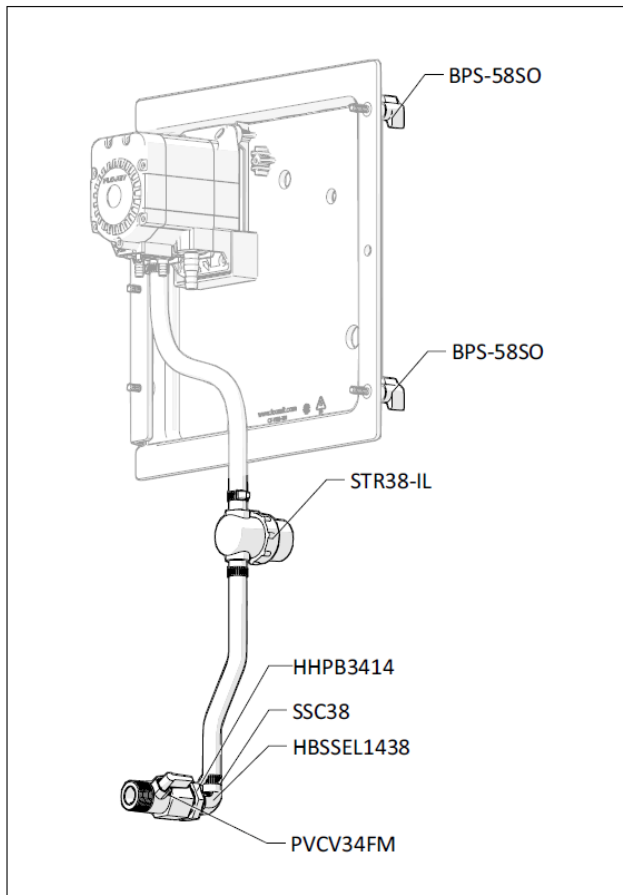
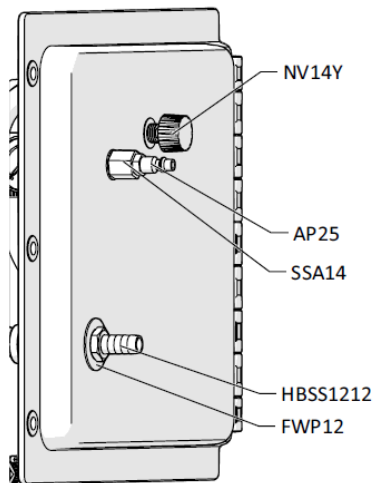



Plate - Back View



OPTIONAL COMPONENTS

<p>WATER SEPARATOR ITEM NUMBER: WS-20CFM</p> 	<p>30 ft (9 m) AIR HOSE ASSEMBLY ITEM NUMBER: AH30</p> 
--	--

READ ALL INSTRUCTIONS BEFORE OPERATING EQUIPMENT

ITEM NUMBER	DESCRIPTION
AG100	1.5 INCH DRY MODEL 20 DUAL SCALE GAUGE
AKSS12	SS ANTI-KINK SPRING FOR 1.2 INCH HOSE WITH PIN
AKSS12-P	SS ANTI-KINK SPRING FOR 1.2 INCH HOSE
AKSS-HPC	ANTI-KINK STAINLESS STEEL HITCH PIN CLIP
AP25	PLUG 1/4 NPTM AIR FITTING - BRASS
AS1-VS	1/4-20 X 1/2 PHIL TRUSS MACH SCREW 19-8 W/516 ORANGE VIBRASEAL PATCH
B8X58	8-15 X 5/8 inch PHIL FLAT TY-A 316 S.S.
BPS-58SO	Back Panel Screw - 5/8 inch with Stand Off
BPS-SSR	1/4 INCH PUSHNUT BOLT RETAINER STAINLESS STEEL
COT	1/8 X 1 COTTER PIN 18-8 S/S
CV38	PVC CHECK VALVE 3/8 BARBS - SS SPRING
DFP7	7 INCH HINDGED CAP INCLUDES LID FLANGE AND HINGE PIN
DFP7-C	7 INCH DRAIN CAP POLYPRO BLACK
DFP7-F	7 INCH TANK LID FLANGE POLYPRO
DFP7-PIN	HINGE PIN FOR DFP7-C & DFP7-C
DFP7-C-BL	7 INCH FILL CAP POLYPRO BLUE PANTONE
DFP7-C-GN	7 INCH FILL CAP POLYPRO GREEN PANTONE
DFP7-C-RD	7 INCH FILL CAP POLYPRO RED PANTONE
DFP7-C-YL	7 INCH FILL CAP POLYPRO YELLOW PANTONE
DP-A	7 INCH HINDGED CAP INCLUDES LID FLANGE AND HINGE PIN
DP	FRONT DRAIN PLUG FOR PORTABLE UNIT POLYPRO
DP-G	FKM SQUARE CUT DRAIN PLUG GASKET
DP-INSERT	304 STAINLESS DRAIN PLUG INSERT
EC12	OETIKER CLAMP 21.0-706R
EC14-2	OETIKER CLAMP 13.8
F12SS	STAINLESS .875 ID FERRULE FOR 1/2 INCH HOSE
F38SS	STAINLESS 3/8 INCH FERRULE
FAC14	FEMALE COUPLER - 1/4in NPTF
FWAX15	FLAT AXLE WASHER
FWP12	7/8 ID X 1.5 OD X 0.05 THK SSFW
FWP14	C-816 1/2in SS WASHER
H12B-H	1/2 INCH BLUE GOODYEAR HORIZON HOSE - Available per ft.
H14B-H	1/4 INCH BLUE HOSE- GOODYEAR HORIZON - Available per ft.
H38B-H	3/8 INCH BLUE GOODYEAR HORIZON HOSE - Available per ft.
HBBF1438	BRASS 1/4in FPT X 3/8in HOSE BARB
HBSS1212	STAINLESS HOSE BARB 1/2 X 1/2
HBSS1438	STAINLESS HOSE BARB 1/4 MPT X 3/8 BARB
HBSSSEL1438	STAINLESS HOSE BARB ELBOW 1/4 INCH NPT X 3/8 HOSE BARB

HBSSSEL1814	304 STAINLESS ELBOW 1/8 INCH NPT X 1/4 INCH HOSE BARB
HHPB3414	HEX HEAD POLY REDUCER BUSHING 3/4 X 1/4
HHSB1214	HEX HEAD S.S. REDUCER BUSHING 1/2 X 1/4
HV60	1/2in STAINLESS BALL VALVE - w/ WELDED NUT
NV14Y	FLOW CONTROL VALVE - INCLUDES BLACK KNOB
NV14Y-HNDL	KNOB FOR 2839-1/4 NEEDLE VALVE
P56	5700 PUMP WITH SANTOPRENE SEALS - INCLUDES HOSE BARBS
P56K	5700 PUMP WITH KALREZ SEALS - INCLUDES HOSE BARBS
P56V	5700 PUMP WITH VITON SEALS - INCLUDES HOSE BARBS
20756103B	Polypro G57 Air Port x HB Straight, w/ Viton o-ring
HB14P	1/4in BRASS HB AIR FITTING /G57/P56
HB5638	HOSE BARB FOR P56 PUMP
HB5638K	HOSE BARB FOR P56K PUMP
HB5638V	HOSE BARB FOR P56V PUMP
P56-BRKT	PUMP BRACKET- STAINLESS STEEL
P56-BRKT-SCREW	HI LO SCREW FOR RETAINING P56-BRKT
PLPF	PORTABLE FOAMER BACK PLATE W/ HINGE AND HOLES
PLPF-PIN	302 STAINLESS PORTABLE PLATE HINGE PIN
PVCV34FM	PVC VALVE 3/4in FPT X 3/4in MPT
PW10	3/4in BLACK POLY PRO X 10in - FPTBE - SCH.80
R25	AIR REGULATOR INCLUDES AIR FILTER AND BOWL
AFR25	AIR FILTER for R25
ABR25	METAL AIR BOWL for R25
S142058-VS	1/4-20 X 5/8 PHIL TRUSS MACHINE SCREW 18-8 W/#516 VIBRASEAL ORANGE PATCH
SN1212	1/2in HEX STAINLESS STEEL NIPPLE
SSA14	SS304 MALE/FEMALE ADAPTOR 1/4 NPT X 1/4 NPT
SSAXLE14	14 1/2" long with the 5/8" diameter bar & 2 through holes with countersinks beveled ends
SSC12	WORM GEAR CLAMP, S/S (.31-.91)
SSC38	WORM GEAR CLAMP, S/S (.25-.63)
SS-MESH	STAINLESS STEEL MESH WITH SSST FOR REPLACEMENT
SSP12	STAINLESS STEEL AXLE PLATE - 2.5 inch X 1 inch - 2 HOLE
SSST	SCREEN DISC .687 DIA. 10 X 10 MESH @ .020 DIA. 300 SERIES S.S.
SST12HB38	STAINLESS TEE COMBO 1/2in FPT X 3/8 in BARB WITH SSST AND S.S. MESH
ST80100	VEEJET NOZZLE, BRASS 80100
STR38-IL	IN LINE STRAINER 3/8 BARB 20 MESH 304 STAINLESS EDPM GSKT
TANK-10N	10 GALLON NATURAL TANK
TW916	1/2 INT TOOTH L/W 410SS
W15	NONMARKING WHEEL FOR PORTABLE UNITS
W8	1/4in S.S. WAND 7IN SS TOE